

STINGER PRO 185cc twin

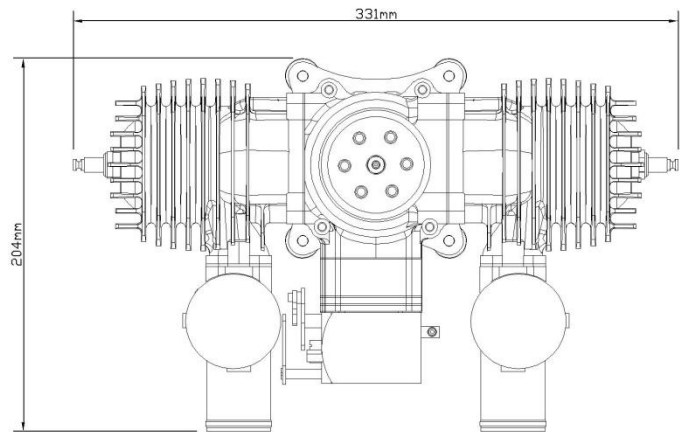
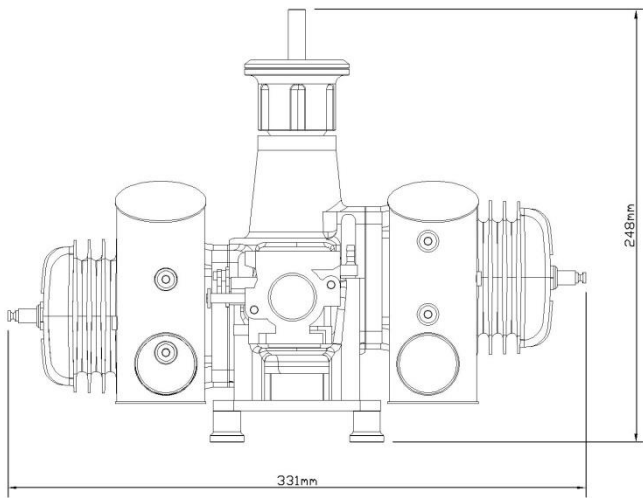

Performance :	22HP/7800rpm
Idle Speed :	1100 rmp/min
Static Thrust :	38 kgs
Recommended Propeller :	30×12 ; 30×13; 31x12; 32×10 ;
Spark Plug Type :	CM6
Displacement :	185 cm3
Diameter :	54mm
Lubrication Ratio :	40:1
Weight of Main Engine :	3680 g
Weight of Exhaust :	460 g
Weight of Ignition :	190g
Ignition voltage:	7V-14V

IMI-HOBBY CENTRUM-IMPORT-EXPORT
www.modelsport.sk
www.modelarstvoimi.sk

IMI-HOBBY CENTRUM
 Bratislavská 9
 949 01 Nitra
 Slovak Republic

Kontakt:
 037/650 66 31
 037/650 66 32
 e-mail: imi@nitra.minitra.sk